



SPECIFICATION

Item No.	SRT D240E
----------	-----------

Reflector

Type	Prime
Diameter	240cm
Panels (Sector Divided)	6 Sectors
Efficiency	70% Min.
C-Band Gain @4.0GHz	38.9dB
Ku-Band Gain @12.5GHz	48.75dB
F/D Ratio	0.38
Focus Length	915mm
3dB Beamwidth	0.7° (@12.4 GHz) / 2.1° (@4 GHz) Max.
Material	Steel
Finish	Polyester Powder Coating
Color	Gray /Cool Gray

Mounting

Mounting Type	Ground Mount
Adjustment Type	AZ Fixed /EL Adjustable
Material	Steel
Finish	Polyester Powder Coating
Color	Gray /Cool Gray
Elevation	0°~90°
Azimuth	Fixed
Square Pole Size	25 X 25 mm

Environment

Ambient Temperature	-40℃~+60℃
Relative Humidity	0~100%

STRONG SRT D240E

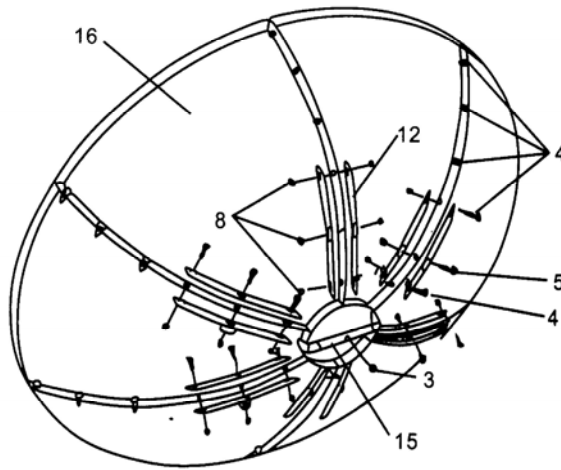
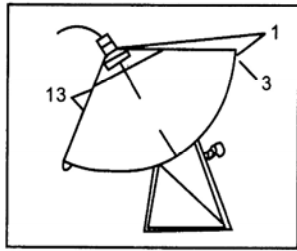
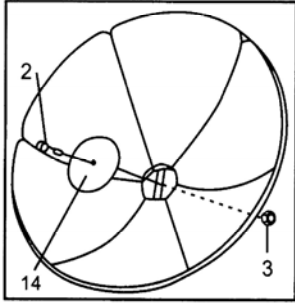

F/D ratio 0.38

No.	specification	Accessory	quantity
1	M6×15	Screw	3
2	M6×55	Square neck screw	1
3	M6	Nut	4
4	M8×15	Screw	30(24)
5	M8×20	Screw	6
6	M8×50	Screw	10
7	M8×60	Screw	2
8	M8	Nut	48(42)
9	30mm	Mount clip	3
10	M8×70	Anchor bolt	6
11	30mm	Connection clip of reflector	6
12		Strengthening board of reflector	12
13	φ 12	LNB arm	3
14		Central round	1
15		crossarm	1
16		reflector	6
17		Connection round	1
18		Mount round	1
19	25×25	Up adjusting arm	1
20	30×30	Down adjusting arm	1
21	30×30	Front support pipe	2
22	φ 16	Front tension bar	1
23	φ 16	Side tension bar	2
24		Plastic hand shank	2

