

## SRT L729 Single Universal Digital LNBF

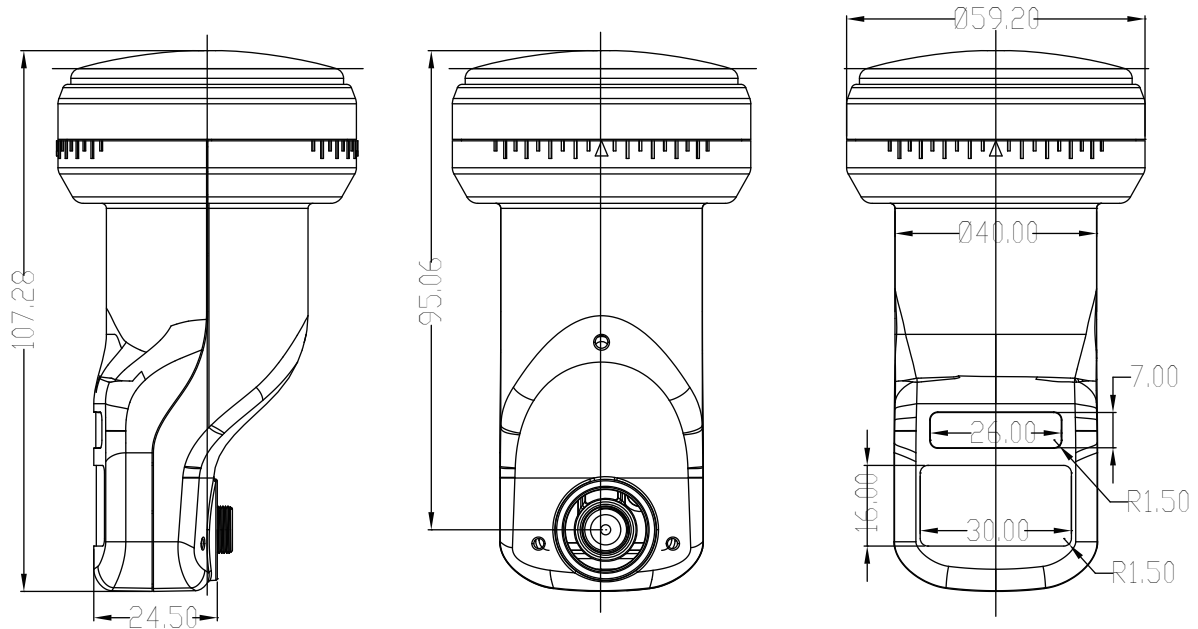

Item		Units	Specification			Note & Test Condition
			Min.	Typical	Max.	
Input Freq. Range	Low - Band	GHz	10.7	-	11.7	
	High - Band	GHz	11.7	-	12.75	
Polarization	-	-	Linear V/H			
Output Freq. Range	Low - Band	MHz	950	-	1950	
	High - Band	MHz	1100	-	2150	
Output VSWR		Ratio	-	2.0 : 1	-	@ 950 ~ 2150 MHz
Output Connector Type		-	75 Ohms Female F- Connector x 1			
Local Oscillator Freq.	Low - Band	GHz		9.75		
	High - Band	GHz		10.60		
Local Oscillator Stability		+ / - MHz			+ / - 3.0	@ - 30 °C ~ + 60°C
Phase Noise Performance	@ 1KHz	dBc / Hz		-55		@ Ta = 25°C
	@ 10KHz	dBc / Hz		-80		
	@ 100KHz	dBc / Hz		-95		
Conversion Gain		dB	-	55	63	
Gain Flatness Over Full Band		dB p-p		8		
Gain Flatness @ Any 26MHz Bandwidth		dB p-p			+ / - 0.75	
Output spurious		dBm	-60			
Noise Figure		dB		0.8		
Cross Pol. Isolation		dB	18			
Image Rejection		dB	40		-	
1dB Compression Point ( Two Tones )		dBm		0	-	@ Two Tones Condition
DC Current Consumption		mA	-	110		
Operating Voltage and Band Switching	Vertical	VDC	11.0	-	14.5	
	Horizontal	VDC	16.0	-	20.0	
	Low - Band	KHz	0			
	High - Band	KHz		22		
Operation Temperature		C	-30	-	60	@ Relative Humidity 95%
Storage Temperature		C	-40		70	